

Breezair[®]
NUMBER ONE IN NATURAL COOLING

The coolest, quietest and most energy efficient evaporative air conditioning in the world!



SEELEY
INTERNATIONAL 

Frank Seeley AM FAICD

Founder and Executive Chairman



Seeley International is Australia's largest and most awarded air conditioning manufacturer with a history spanning more than 40 years.

Renowned for ingenuity and innovation, Seeley International leads the market in the design and manufacture of heating and cooling systems, with award winning brand names including Breezair, Braemar, Climate Wizard, Convoir, Coolair and Coolerado.

With factories in Adelaide, South Australia and Albury, New South Wales, when you buy a Seeley International product you can be confident you're investing in a quality, Australian made climate control solution.

Seeley International never stops striving to engineer and build the world's most energy efficient heaters and coolers. It is this commitment to excellence that's at the heart of everything we do.

For Breezair, the product range is made in Australia.

For Braemar, the evaporative and gas heating product ranges are made in Australia. The inverter add-on cooling product range is assembled in Australia.

For Climate Wizard, the product range is made in Australia.

For Convoir, the evaporative product range is made in Australia.

For Coolair, the product range is made in Australia.

For Braemar Tudor Romeo, the product range is made in Australia.

For Coolerado, the product range is made/assembled in the US.



Just a few recent awards...

Seeley International is delighted to have been repeatedly recognised for innovation and excellence.

CCN Awards 2015

Winner: HVAC&R Leader of the Year

Frank Seeley AM FAICD

The Australian Business Awards 2015

Winner: Best New Product

Braemar 7 star equivalent* ducted gas heater

Good Design Awards 2015

Winner: Product Design: Hardware and Building category

Braemar 7 star equivalent* ducted gas heater

BRW Most Innovative Companies List 2015

Top 50 Most Innovative Companies

Seeley International Pty Ltd

BRW Momentum Mid-Market Leaders Awards 2014

Winner: Best Mid-Market Business

(revenue \$100 million to \$250 million p.a.)

Seeley International Pty Ltd

Australian Design Awards 2014

Winner: Good Design® Selection

MagiQtouch Controller

United Nations Association of Australia

World Environment Day Awards 2014

Winner: Swinburne University of Technology Excellence in Sustainable Product Design Award

Braemar "Super-Six" ducted gas heating

Melbourne Design Awards 2013

Winner: Product Design: Housing & Building Awards

Braemar "Super-Six" ducted gas heating

Family Business Australia

Winner: Award for Entrepreneurship 2013

Frank Seeley AM FAICD



why Breezair?

When you choose a Breezair product, you know you're choosing prestige quality, leading-edge technology and super cool energy efficiency for your family.



Lowest running costs in the world with unbeatable energy efficiency*



Global leaders in design and performance



Quality that makes it easy for us to give our 7 year comprehensive warranty^



50 year history of Australian excellence



Australian made - *a wise Australian buys Australian!*

*Correct at time of printing.

^The 7 year comprehensive warranty is available exclusively (i.e. only) from Seeley International participating dealers. The warranty has terms and conditions, including the requirement for servicing of the product in accordance with the owner's manual. In the fourth year the service must be performed by Seeley International or its appointed nominee.



why Breezair evaporative cooling?

Breezair evaporative cooling is the best choice for longevity, energy efficiency and comfort.



Up to 90% cheaper to run compared to reverse cycle cooling*



There is simply nothing else in its class!



Whisper-quiet cooling



Built entirely in Australia to withstand the harshest climates on the planet



Lowest maintenance costs, **by far!**



Delivers fresh, filtered, healthy outside air



Low CO₂ emissions, the right choice for the environment



Superb whole-of-home cooling





* Refer to page 4.

Cool your whole home from the cost of running a single light globe!

Why choose evaporative over reverse cycle cooling?

With energy prices spiralling ever upwards and our summers getting hotter, evaporative cooling has a significant and increasing edge on reverse cycle, when it comes to energy efficiency, performance and lifestyle.

Breezair is the world's first inverter evaporative cooler, providing super savings and superb cooling!

-  Cool your whole home from the cost of running a light globe
-  Leave windows and doors open so air is fresh and healthy
-  Won't dry your skin, nose and eyes
-  Energy efficiency means better for the environment
-  Get a good night's sleep with whisper-quiet cooling

BREEZAIR IS THE QUIETEST & MOST ENERGY EFFICIENT WHOLE-OF-HOME COOLING SYSTEM IN AUSTRALIA & THE WORLD!

saving you up to \$346 per year as compared to a ducted reverse cycle system.

Running cost comparison*

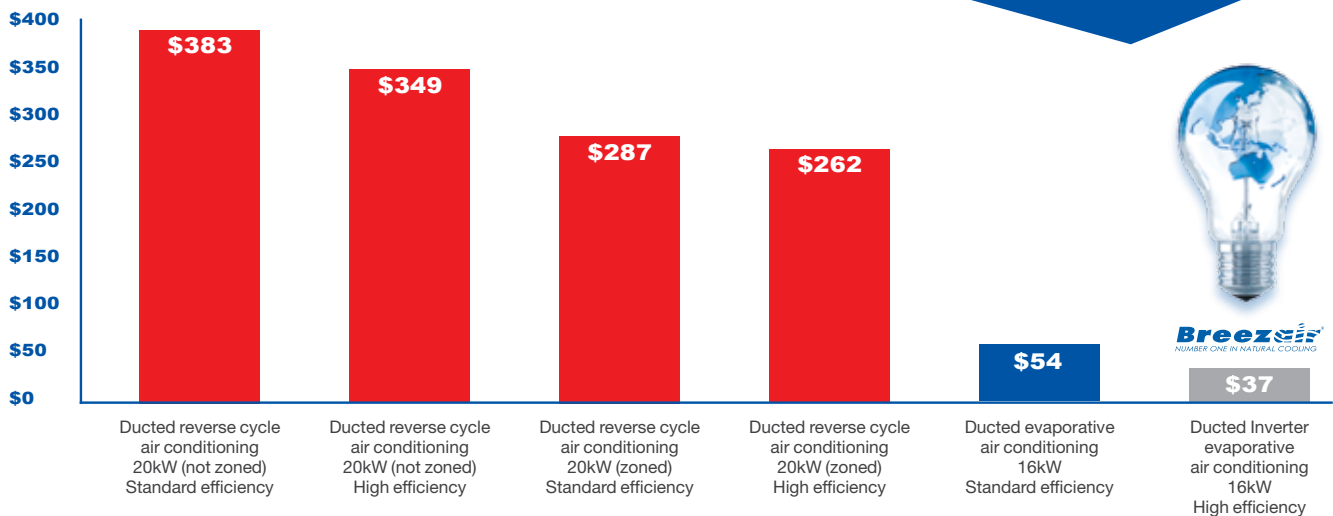

*Based on approximate running cost figures per annum sourced from Sustainability Victoria – see its Cooling Fact Sheet at www.sustainability.vic.gov.au. Assumes a whole house area of 166 square metres, with 300 hours usage, a 60% duty cycle for air conditioners, and an electricity tariff of 28 cents/kWh. No brand names are mentioned in the Sheet. Note that evaporative coolers also use water.

How much water will your Breezair use?

Litres/year	Household use
5,405	Breezair evaporative air conditioning 14.8 L per day
6,570	Dishwasher 1 x 18 L capacity per day
6,570	Washing dishes 1 x 18 L capacity per day
21,900	Washing machine (front loader) 60 L per cycle - 1 wash per day
29,200	Bath (1/2 full) 1 x 80 L capacity per day
48,600	Garden sprinkler 1 hour every 2nd day in Summer only
54,750	Washing machine (top loader) 150 L per cycle - 1 wash per day
58,400	Toilet (dual flush 8L) 4 person home - 5 times per person per day
116,800	Shower (water-efficient showerhead) 5 people - 10 min per person per day
248,200	Shower (ordinary showerhead) 4 people - 10 min per person per day

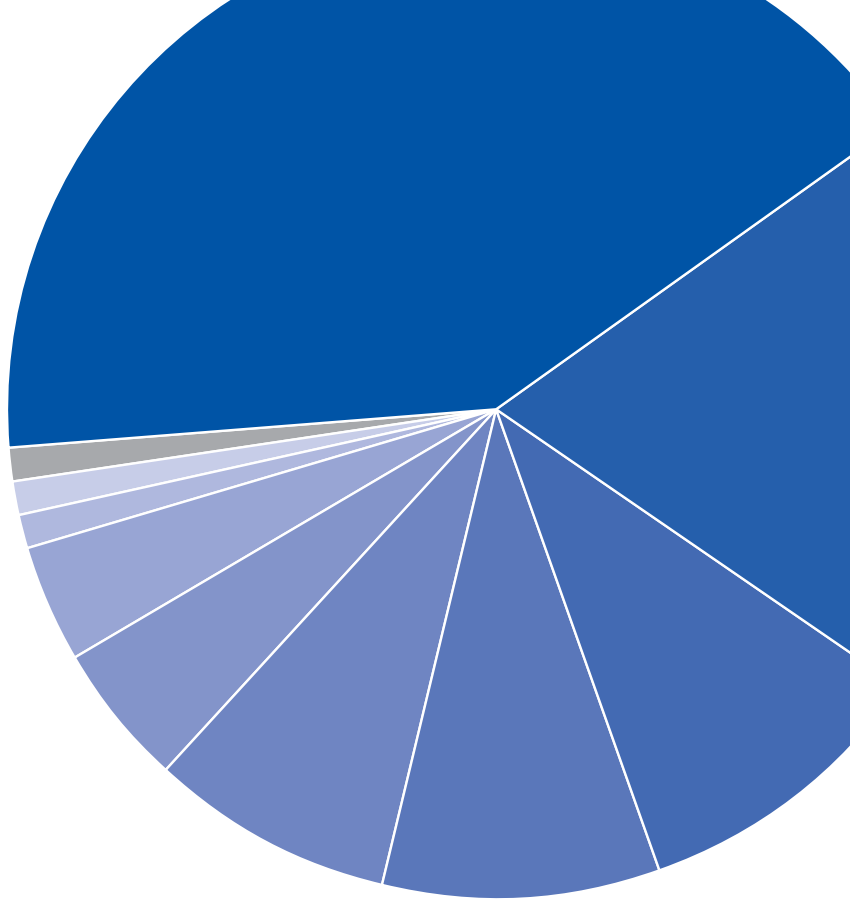

Source: South East Water Corporation, Article: 'How much water do my appliances use', www.southeastwater.com.au, 2014.
Breezair data is not in the Article, but is based on Melbourne 2005 weather data using 115m² house with medium to large Breezair evaporative unit running for 687 hours per year.
Note: All figures are based on common-use assumptions.

CO₂ emissions (kg/yr)*

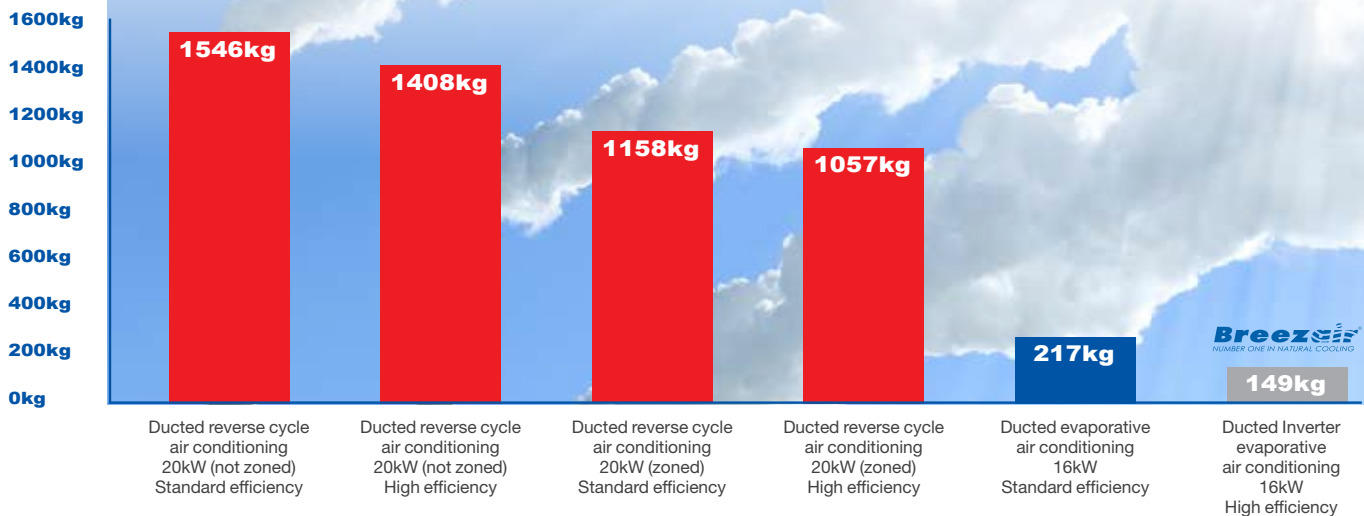

* Seeley International's calculations, based on publicly available data (2008). CO₂ emissions based on 1.13 kg CO₂ e/kWhr electricity purchased from grid for Victoria.
Data sourced from Part 6 of Schedule 1 to the National Greenhouse and Energy Reporting (Measurement) Determination 2008 (Compilation No. 7, dated 1 July 2015).

Breezair ducted evaporative cooling

Features and benefits

Drain and clean function

- Automatic water draining when the system is not in use
- Avoids algae growth
- Removes the need for seasonal maintenance required by competitor products*



*Seasonal maintenance is done at the start and end of each summer season. Regular maintenance as per the owner's manual (typically every 2 years) is still required.

Note: This feature is only available with Harmony MagIQtouch Controller.

Non clogging water distribution

- Unique design ensures constant, even pad saturation
- Increases the cooling effect - outperforms competitor products



Tornado® pump

- Australian designed and manufactured
- Exceptional reliability in extreme conditions



Long life Chillcel® pads

- Honeycomb design optimises the cooling effect
- Durable composition outlasts competitor products
- Pre-wet function allows the pads to be completely saturated before the fan comes on so only fully-cooled air leaves the unit.



WaterMiser®*

- Uses the minimum amount of water to achieve high efficiency cooling
- Water quality monitoring to maximise water savings
- Leak detection monitor



*Optional on the EXQ series, only available with the Harmony MagIQtouch Controller



Optional extras

Firewall Auto-seal

- Helps prevent ember attack in bushfires
- Metal flap that isolates the cooler from the duct work
- When fitted, the Breezair unit complies with:
 - Bushfire Attack Level rating BAL-LOW through to BAL-29 (AS3959)
 - The Building Code of Australia

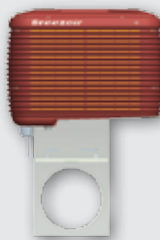

Firewall ember screen

- Helps guard against ember attack in bushfires
- Made from non-combustible mesh
- Maximum aperture of 2 mm
- Can be fitted to existing cooler pad frames
- Minimal reduction of air flow of 5%

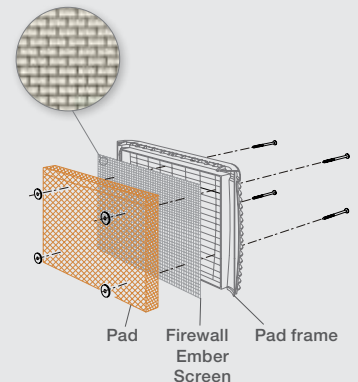

Exciting brand new features revealed overleaf!



Icon® series fan

- Combined motor and fan
- Ultra-quiet centrifugal fan with 10 speeds
- Use Fan Only mode (no water) to blow fresh air through the home and expel odours
- Proactively responds to duct sizing and back-pressure
- Designed to deliver optimum air output at all times



Hushpower® direct drive InvertaCool motor

- Exclusive to Breezair
- Incredibly quiet and efficient throughout operating range
- Uses far less energy
- Unsurpassed reliability
- Corrosion-proofed throughout



Mirage rooftop unit

- The Mirage models' raked-base design and low profile hugs the slope of your roof
- Visually discreet - hidden from the street



Power control module

- Advanced electronics ensure optimum efficiency
- Microprocessor constantly analyses water quality, water consumption and power output
- Exceptionally smart, incredibly reliable and amazingly durable



Weatherseal®

- Automatic sealing system
- Reduces draughts and dust
- Reduces need for winter cover



Warranty

For complete peace of mind, a rigid quality control testing policy to International Standard ISO 9001 ensures that Breezair Icon series air conditioners live up to their well-earned reputation for outstanding reliability.



For additional peace of mind, Breezair backs every one of its air conditioning systems with an industry leading comprehensive warranty program - including a 7 year warranty, 10 year cover on all structural components, plus a hefty 25 year cover on its Permatuf® cabinets.

National service agent network

For your convenience and peace of mind, Seeley International has established a highly trained national network of approved Service Agents who are only a phone call away. Should you need to contact a Service Agent, please call 1300 650 644.

*The 7 year comprehensive warranty is available exclusively (i.e. only) from Seeley International participating dealers. The warranty has terms and conditions, including the requirement for servicing of the product in accordance with the owner's manual. In the fourth year the service must be performed by Seeley International or its appointed nominee.

Innovative MagIQtouch Controller

Touch screen technology

Operating your Breezair with its MagIQtouch Controller is a breeze. Smart, sophisticated and incredibly intuitive, its discreet and modern design will blend seamlessly into the décor of your home.

As easy to use as your familiar touch screens, this controller's intuitive user navigation system makes operating simple.

Keeping your home and your family cool in summer is easy and economical with the MagIQtouch Controller and your Breezair evaporative air conditioner.

NEW

Auto clean function

This new world first fully automated pad cleansing capability enables you to just **set and forget**. This ensures your cooling pads remain clean, fresh and functional all summer long and season after season.*

*Only for cooler models fitted with the water management system. Ask your dealer for further information.

Service alert

Informs you when your Breezair cooler needs to be serviced.

Energy saving night quiet mode

When turned on, the Energy saving "night-quiet" mode automatically reduces fan speed overnight for even *greater* economy and "whisper-quietness".

Personalised cooling

If you want to "set and forget" a seven-day program that suits your lifestyle, then Breezair's Program mode is for you.

Program mode divides each day into four time periods. You decide when each of these periods begins and what you want your system to be doing.

But you can have flexibility as well. If you leave or arrive home early, you can easily skip forward to the next period. The program will take over again once the next time period begins.

Customisable

There is no need to display advanced functionality if it isn't required. You have the choice to view simple or advanced displays.

In simple display you can set your mode and temperature and let the MagIQtouch Controller do the rest! Or, if you would like access to more advanced features, by touching 'More' you can select manual temperature mode, manual fan speed mode, or program mode and access other settings.



MAGIQTOUCH

AIR SENSOR



(optional extra)

Allows you to mount your MagIQtouch Controller in the most convenient place in your home, as the MagIQtouch Air Sensor will then take over temperature control from the MagIQtouch Controller. This can then be located in the best place in the house to ensure ultimate cooling comfort for everyone.



*The 7 year comprehensive warranty is available exclusively (i.e. only) from Seeley International participating dealers. The warranty has terms and conditions, including the requirement for servicing of the product in accordance with the owner's manual. In the fourth year the service must be performed by Seeley International or its appointed nominee.

**Optional on the EXQ series and is only available with the Harmony MagIQtouch Controller. Note: All other features are available on EXQ and EZQ models and are compatible with both the Homemaker and Harmony MagIQtouch Controllers.



Program mode

Settable 7 day, 4 time periods program, customisable to suit your lifestyle (including a temporary over-ride function).



Date and time

Date and time displays appear on all operation screens.



Child access lock

Select a pin code to control access to your Controller.



About appliance

Displays information about your appliance including serial number, model number, and software version.



Adjustable working temperature range

Customise the temperature range displayed on the slider.



Status information

When this option is turned on, a temporary information display window becomes accessible on all Manual and Program screens to aid in troubleshooting.



Screen brightness adjustment

Adjust the brightness of the screen when in standby mode, to suit your home and preference.



Inbuilt diagnostics

If a fault is detected in the system, a fault message dialogue box will appear with information about the fault and options available to resolve the issue.



Auto drain and dry**

This optional function allows you to set a schedule to automatically drain water from the tank and run the fan for an extra hour to blow the pads dry, this enhances the prevention of algae growth and prolongs the life of your Chillcel pads.



Manual drain**

This function turns the cooler off at the press of a button and drains the tank filling with fresh water.



Pad flush

Ideal for bushfire prone areas. Pad flush turns the cooler off and runs the pump continuously, or for a set time.



Auto restart

Option to automatically restart your cooler after a power outage.

Breezair Icon range

The Breezair range is the **ONLY** evaporative air conditioner with

InvertaCool™ inverter technology

giving you amazing innovation that saves you lots of money on your operating costs year after year.

ICONomy

/aɪkɒn.ə.mi/

verb

1. The art of saving money through the acquisition of a Breezair Icon evaporative cooler.



Cool your whole home from the cost of running a single light globe!

Breezair specifications



Model	EXQ130	EXQ150	EXQ170	EXQ190	EXQ210	EZQ215**
Width (mm)	1160	1160	1160	1160	1160	1160
Depth (mm)	1160	1160	1160	1160	1160	1160
Height (mm)	660	860	860	860	860	1240
Operating weight (kg)	78	84	84	84	85	94
Nominal power motor (W)	500	550	750	1100	1500	1500
Airflow (L/sec)	1330	1760	2090	2360	2540	2620
Cooling capacity (kW)	6.5	9.4	10.6	11.4	12.3	12.9

*Colours may vary.

**Model EZQ215 is available in slate grey and terracotta colours only.

The above data was drawn from Meridian Test Laboratory's test analysis. The testing was performed by a NATA accredited laboratory to the requirements of the Australian standard AS2913-2000 "Evaporative Air Conditioning Equipment." Achievable with ambient 38 °C DB, 21 °C WB, room temperature 27.4 °C.

Knowledge, expertise and support

Your experienced Seeley International dealer is always available to provide you with expert advice.

They're fully trained to help you choose the best climate control system to suit your family, your lifestyle and your budget.

CompuComfort™ sizing system app

For a smarter installation, CompuComfort is another brilliant example of Seeley International's innovation.

Exclusive to your Seeley International dealer, the intelligent CompuComfort design program uses a unique web application to accurately profile your home's key architectural aspects. CompuComfort considers a variety of factors such as solar and thermal gains, insulation values and other considerations to ensure the most ideal system design is specified for your particular requirements and complete satisfaction.

COMPUCOMFORT™



Looking for a combined cooling and heating solution?

Seeley International's range of products also includes ducted gas heating that complements your evaporative cooling system. Take advantage of controlling your cooling and heating systems from the *same controller* – the innovative touch screen MagIQtouch Controller. Ask your dealer for the right solution for your home.



SEELEY INTERNATIONAL



Seeley International is Australia's largest air conditioning and ducted gas heating manufacturer and a global leader in developing ingenious, energy-efficient cooling and heating products.

Our vision is to lead the world in creating climate control solutions which continue to be highly innovative, of premium quality and inspirational in their delivery of energy-efficiency.

But it's more than just a vision... it's a way of life!

A commitment to innovation and excellence is at the heart of all that we do. Our success in delivering on that commitment has been recognised by our many awards and our expanding global presence. Seeley International now exports to over 120 countries. Not bad for a company that started out in 1972 in the garage of its founder and Executive Chairman, Frank Seeley AM FAICD, who was named South Australian of the Year for 2011!

Seeley International offers a range of heating and cooling solutions, many of which can be combined.

	Ducted evaporative cooling	Indirect evaporative cooling	Ducted gas heating	Reverse cycle air conditioning & add-on cooling	Portable heating / cooling	Wall furnaces & space heaters	Gas cooktops
Breezair	✓						
Braemar	✓		✓	✓		✓	
Climate Wizard		✓					
Convair					✓		
Coolair	✓						
Braemar Tudor Romeo							✓
Coolerado		✓					

To locate your nearest accredited Breezair dealer call **1300 360 651** or go to **breezair.com.au**

Please visit breezair.com.au to find out about our current promotions.*

*Promotions are seasonal and do not run at all times of the year.



Seeley International Pty Ltd
ABN 23 054 687 035

112 O'Sullivan Beach Road, Lonsdale, South Australia 5160

Phone (08) 8328 3850 Fax (08) 8328 3951

Email marketing@seeleyinternational.com
seeleyinternational.com

Information in this brochure was correct at the time of preparation. E & OE